

Başarı Hikayesi

Endüstri: Yiyecek ve İçecek

Uygulama: Oven Fan Unit

Toplam Maliyet Tasarrufu: € 34 907

Uygulama Geçmişi

A leading UK Bakery was experiencing regular, unexpected production stoppages, due to premature failure of pillow block ball bearing mounted units, fitted to a high temperature oven re-circulation fan unit. This resulted in significant disruption to production, high downtime costs and spoilt product. NSK conducted a full evaluation of the application incl. failed bearing analysis and concluded that the bearings were seizing from excessive pre-loading and incorrect lubrication selection on installation. NSK proposed Plummer Blocks with high capacity Spherical Roller Bearings and Labyrinth seals, and recommended the correct bearing location and lubrication. This solution resulted in an immediate improvement and significant service life extension by a factor of 4.5 times.

Temel Bilgiler

- High temperature oven re-circulation fan unit - vertical orientation and belt driven
- Existing bearings not adequate for operating conditions
- Frequent bearing failure occurring every 6 weeks
- Bearing failure resulted in substantial machine downtime and costly loss of production
- NSK proposed SNN Plummer Blocks with high capacity Spherical Roller Bearings and Labyrinth seals, with recommendations on correct bearing location and lubrication
- Bearing life extended from 6 weeks to 27 weeks
- Large cost saving generated by improving production efficiency and equipment reliability



↑ Oven Re-Circulation Fan Unit

Değer Önerisi

- Following repeated and costly bearing failures the customer requested a solution to their problem on an over re-circulation fan unit.
- NSK Application Review determined the bearings had failed from excessive pre-loading and inadequate lubrication.
- NSK proposed SNN Plummer Blocks with HPS Spherical Roller Bearings and Labyrinth seals, with recommendations on correct bearing location and lubrication.
- A trial was conducted using the NSK recommendations with a 4.5 times life extension.
- This resulted in a reduction of machine downtime and maintenance costs and a significant annual cost saving

Ürün Özellikleri

- Equipped with 2 lubrication holes and 1 draining hole
- Solid corners in the base for locating pins
- Square shape and centre marks
- Easy assembly, easy alignment, low maintenance costs
- High rigidity (minimises deformation of the bearing seat)
- Comprehensive range of sealing & arrangements to match all needs
- Good heat transfer
- Same housing can be used with both double row self-aligning ball bearings or double row spherical roller bearings

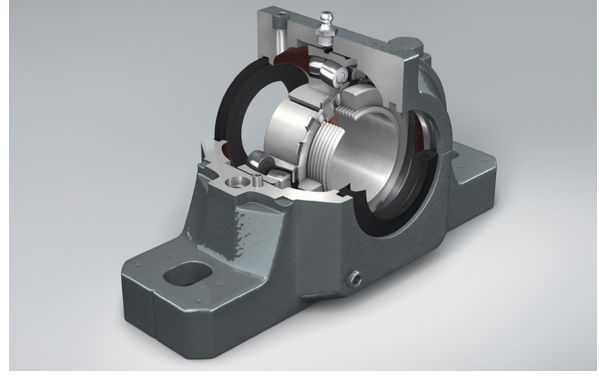

↑ Plummer Blocks with high capacity Spherical Roller Bearings and Labyrinth seals

Maliyet Tasarrufu Dökümü

Önce

Yıllık Maliyet

NSK Çözümü

Yıllık Maliyet

| | | | | |
|---|---|-----------------|---|----------------|
|  | 2 bearing units replaced 9 times per year | € 14 171 | Initial installation plus 2 bearing units replaced twice per year | € 2 873 |
|  | € 550/hr x 5 hr replacement time x 9 breakdowns per year | € 24 750 | € 550/hr x 5 hr replacement time x 2 breakdowns per year | € 5 500 |
|  | 2 Maintenance Technicians x 5 hrs/breakdown x 9 breakdowns/yr | € 2 565 | 2 Maintenance Technicians x 5 hrs/breakdown x 2 breakdowns/yr | € 855 |
|  | Spoiled product | € 3 406 | Spoiled product | € 757 |
| Toplam Maliyet | | € 44 892 | | € 9 985 |